

## 1KSTP12

**DESCRIZIONE** Cappa STEEL parete modulo da 120  
**DESCRIPTION** 120 cm module STEEL wall cooker hood

**PESO LORDO** 41.1 Kg  
**GROSS WEIGHT**

**DIMENSIONI IMBALLO** 1270x640x610 mm  
**PACKAGING DIMENSIONS**

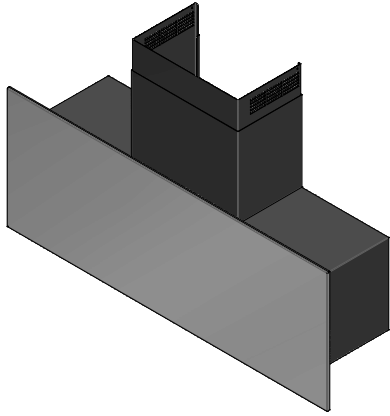

**(A) PULSANTIERA (PUSHBUTTON)** **(B) FILTRI [ACCIAIO INOX] (FILTERS)**

**(C) ILLUMINAZIONE LED (LED LIGHTING)**

- Acciaio inox AISI 304 (AISI 304 stainless steel)
- Aspirazione filtrante opzionale (Optional filter extraction)
- Velocità: 3 + aspirazione intensiva (Speed: 3 + intensive speed)
- Portata nominale motore: 800 m3/h (Engine flow: 800 m3/h)
- Portata Booster: 720 m3/h (Booster flow: 720 m3/h)
- Pressione: 501 Pa (Pressure: 501 Pa)
- Rumorosità: 39-65 Lw[dBA] (Noisiness: 39-65 Lw[dBA])
- Uscita aspirazione: Ø 150 mm + riduttore Ø 120 mm (Duct exit: Ø 150 mm + reducer Ø 120 mm)
- Illuminazione: Barra LED [Temperatura = 4000 K] (Lighting: LED bar)
- Filtri: acciaio inox (Filters: Stainless steel)
- Camino telescopico: H 77.5 - 105.5 (Telescopic hose: H 77.5 - 105.5)
- Classe energetica: A (Energetic class: A)
- Potenza nominale motore: 0.3 kW (Rate engine power: 0.3 kW)

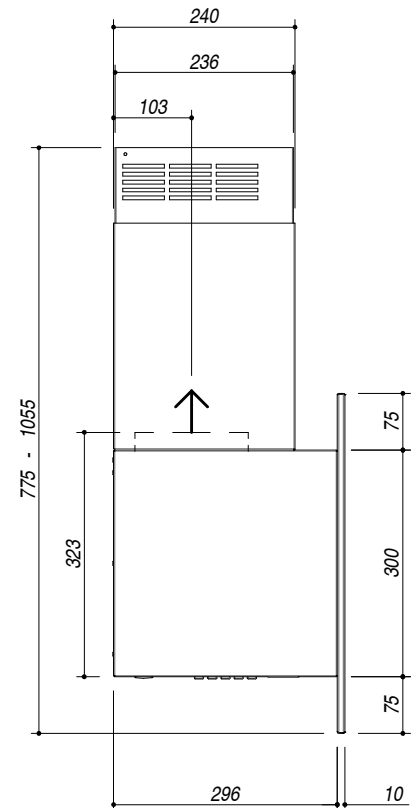
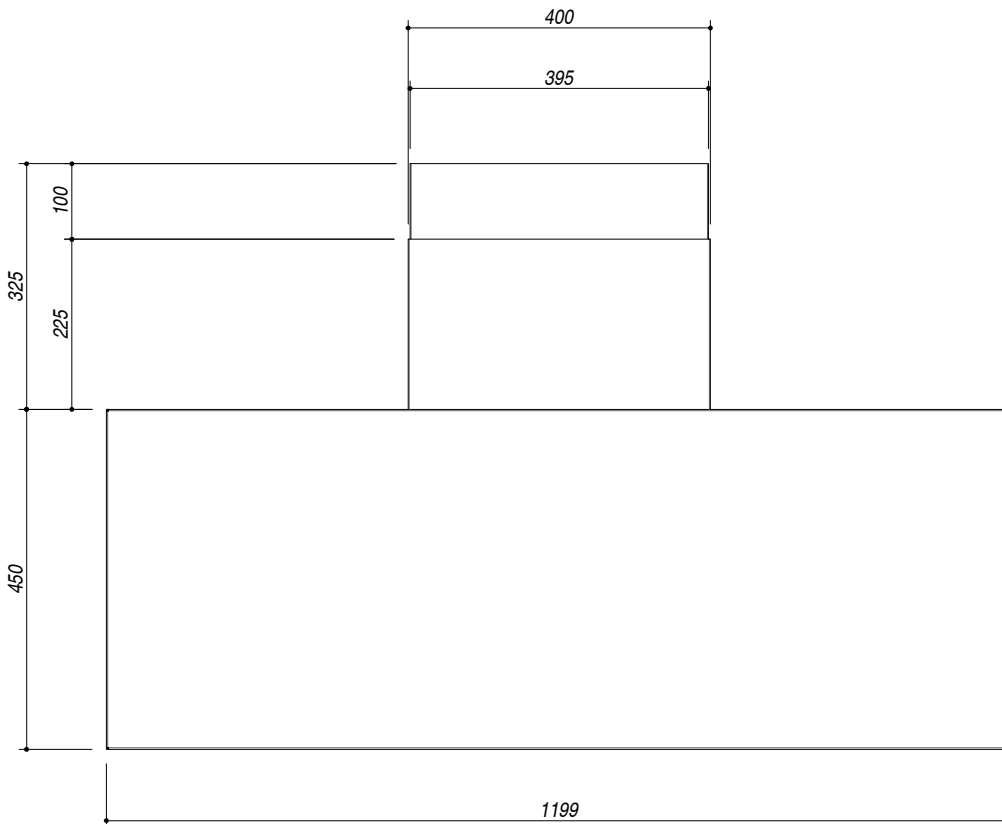
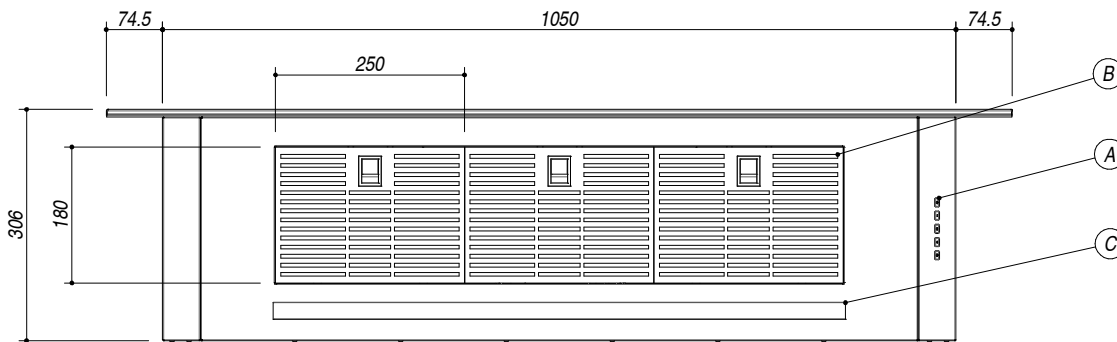

**SCALA DISEGNO** 1:10  
**DRAWING SCALE**



**TUTTE LE MISURE IN mm**  
**ALL MEASURES IN mm**

**TOLLERANZA LINEARE: ± 0.5 mm**  
**LINEAR TOLERANCE**

**TOLLERANZA ANGOLARE: ± 0.2 °**  
**ANGULAR TOLERANCE**