

## 1KSTI9

**DESCRIZIONE** Cappa STEEL isola da 90  
**DESCRIPTION** 90 cm module STEEL island cooker hood

**PESO LORDO** 50 Kg  
**GROSS WEIGHT**

**DIMENSIONI IMBALLO** 960x640x610 mm  
**PACKAGING DIMENSIONS**

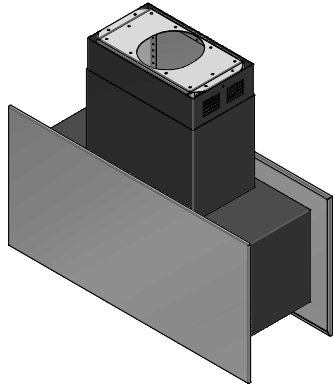

Ⓐ **PULSANTIERA (PUSHBUTTON)** Ⓑ **FILTRI [ACCIAIO INOX] (FILTERS)**

Ⓒ **ILLUMINAZIONE LED (LED LIGHTING)**

- Acciaio inox AISI 304 (AISI 304 stainless steel)
- Aspirazione filtrante opzionale (Optional filter extraction)
- Velocità: 3 + aspirazione intensiva (Speed: 3 + intensive speed)
- Portata nominale motore: 800 m3/h (Engine flow: 800 m3/h)
- Portata Booster: 720 m3/h (Booster flow: 720 m3/h)
- Pressione: 501 Pa (Pressure: 501 Pa)
- Rumorosità: 39-65 Lw[dBA] (Noisiness: 39-65 Lw[dBA])
- Uscita aspirazione: Ø 150 mm + riduttore Ø 120 mm (Duct exit: Ø 150 mm + reducer Ø 120 mm)
- Illuminazione: Barra LED [Temperatura = 4000 K] (Lighting: LED bar)
- Filtri: acciaio inox (Filters: Stainless steel)
- Camino telescopico: H 77.5 - 105.5 (Telescopic hose: H 77.5 - 105.5)
- Classe energetica: A (Energetic class: A)
- Potenza nominale motore: 0.3 kW (Rate engine power: 0.3 kW)

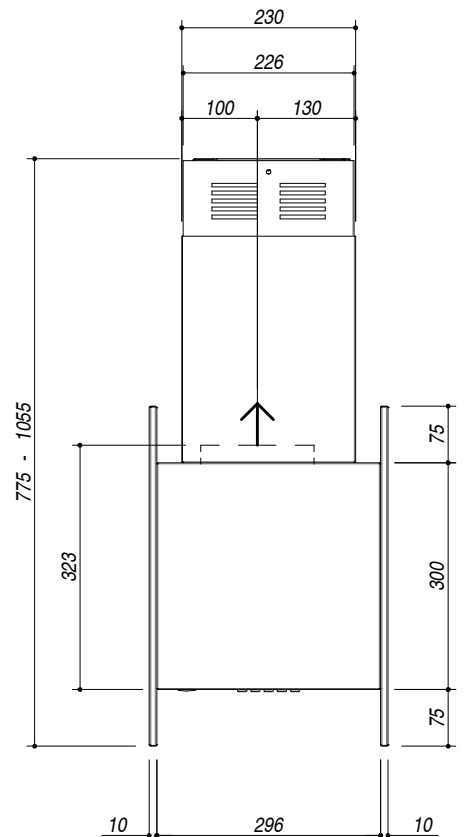
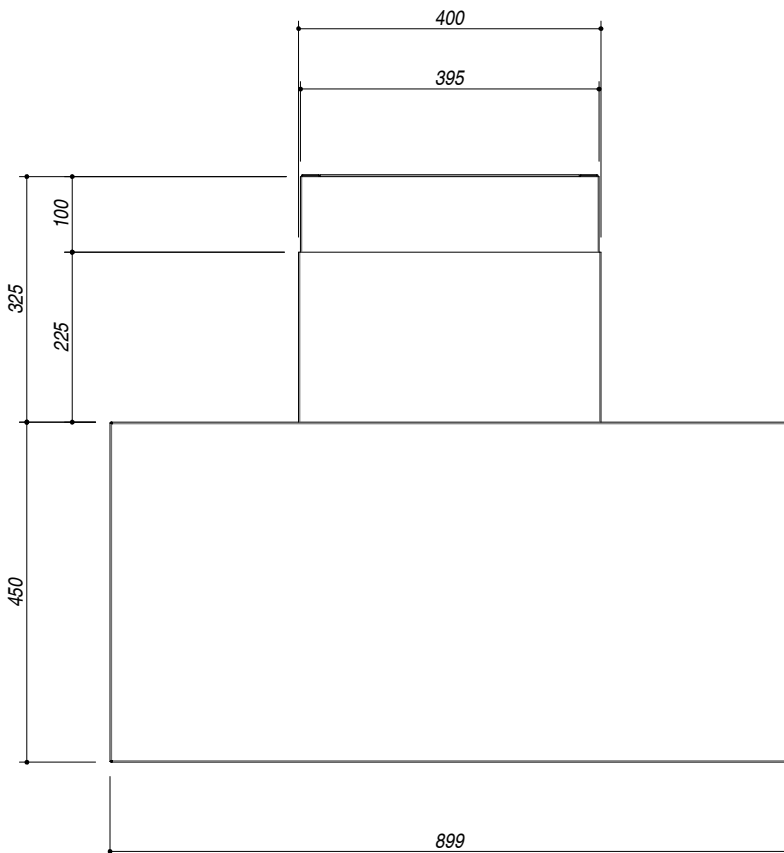
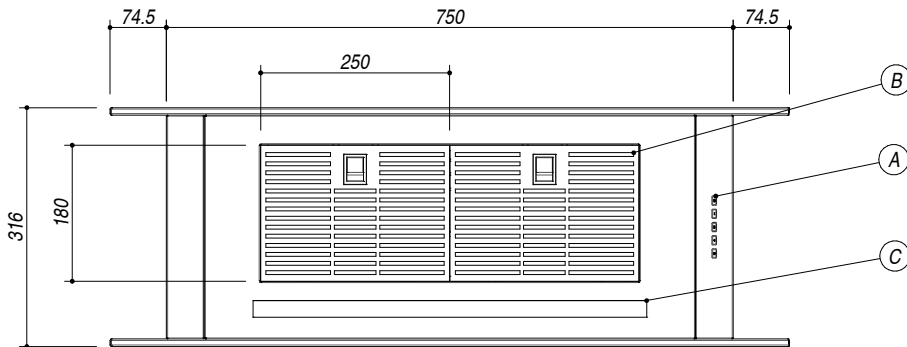

**SCALA DISEGNO** 1:10  
**DRAWING SCALE**



**TUTTE LE MISURE IN mm**  
**ALL MEASURES IN mm**

**TOLLERANZA LINEARE: ± 0.5 mm**  
**LINEAR TOLERANCE**

**TOLLERANZA ANGOLARE: ± 0.2 °**  
**ANGULAR TOLERANCE**

PER QUALSIASI CONTESTAZIONE SI FARA' RIFERIMENTO ESCLUSIVAMENTE A QUESTO DISEGNO  
 For any dispute the company will refer exclusively to this drawing

BARAZZA Barazza s.r.l. - Via Risorgimento, 14 - 31025 Sarano di S. Lucia di P. (TV) Italy  
 Tel. +39/0438/62888 - Fax +39/0438/64901 info@barazzasrl.it - www.barazzasrl.it  
 Documento di proprietà aziendale. La Società tutela i propri diritti a termini di legge.

