

1KSTI12

DESCRIZIONE Cappa STEEL Isola da 120
DESCRIPTION 120 cm module STEEL Island cooker hood

PESO LORDO 53.1 Kg
GROSS WEIGHT

DIMENSIONI IMBALLO 1270x640x610 mm
PACKAGING DIMENSIONS

Ⓐ **PULSANTIERA (PUSHBUTTON)** Ⓑ **FILTRI [ACCIAIO INOX] (FILTERS)**

Ⓒ **ILLUMINAZIONE LED (LED LIGHTING)**

- Acciaio inox AISI 304 (AISI 304 stainless steel)
- Aspirazione filtrante opzionale (Optional filter extraction)
- Velocità: 3 + aspirazione intensiva (Speed: 3 + intensive speed)
- Portata nominale motore: 800 m3/h (Engine flow: 800 m3/h)
- Portata Booster: 720 m3/h (Booster flow: 720 m3/h)
- Pressione: 501 Pa (Pressure: 501 Pa)
- Rumorosità: 39-65 Lw[dBA] (Noisiness: 39-65 Lw[dBA])
- Uscita aspirazione: Ø 150 mm + riduttore Ø 120 mm (Duct exit: Ø 150 mm + reducer Ø 120 mm)
- Illuminazione: Barra LED [Temperatura = 4000 K] (Lighting: LED bar)
- Filtri: acciaio inox (Filters: Stainless steel)
- Camino telescopico: H 77.5 - 105.5 (Telescopic hose: H 77.5 - 105.5)
- Classe energetica: A (Energetic class: A)
- Potenza nominale motore: 0.3 kW (Rate engine power: 0.3 kW)

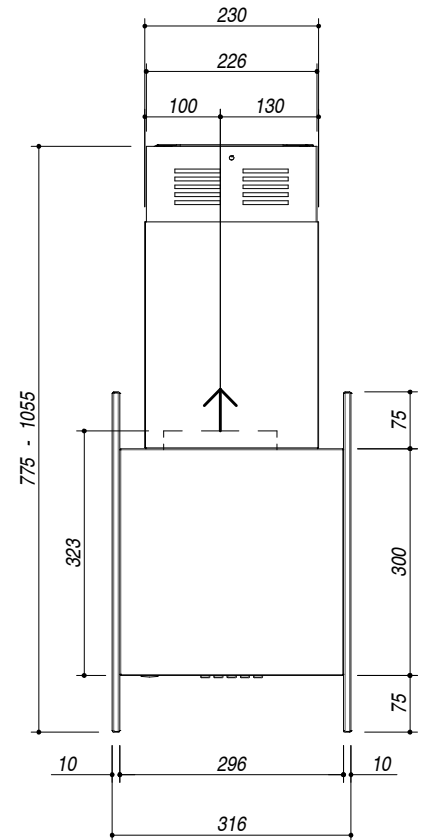
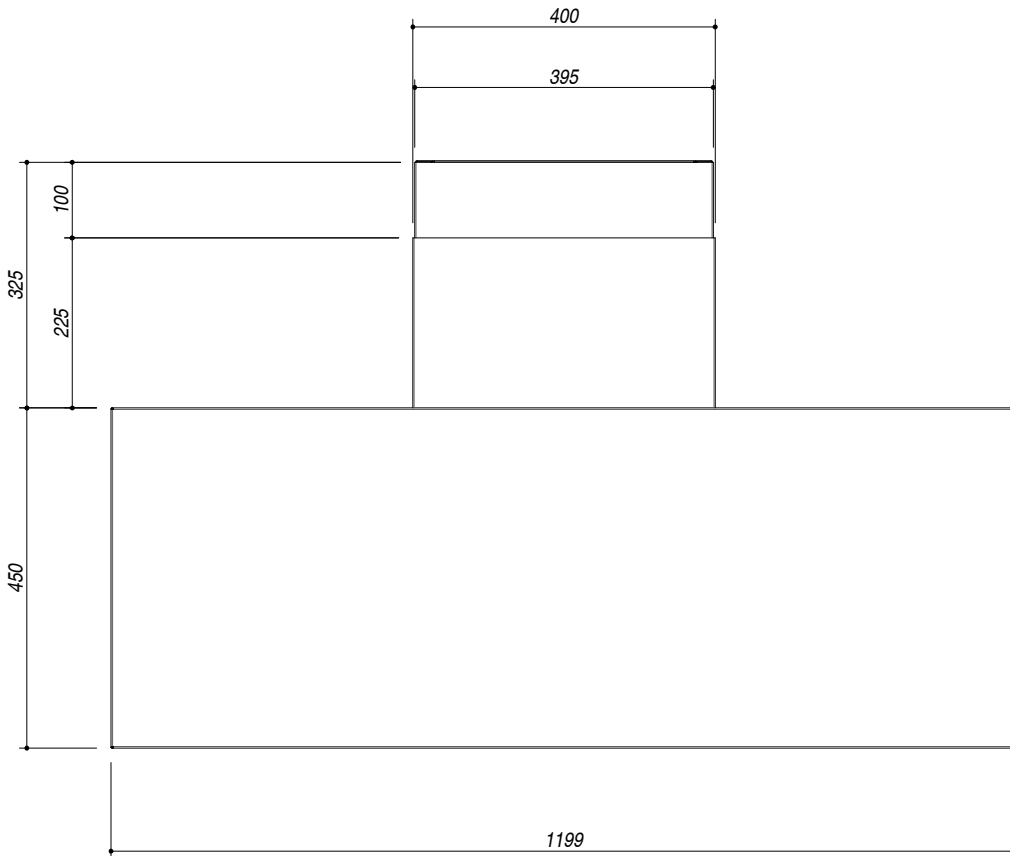
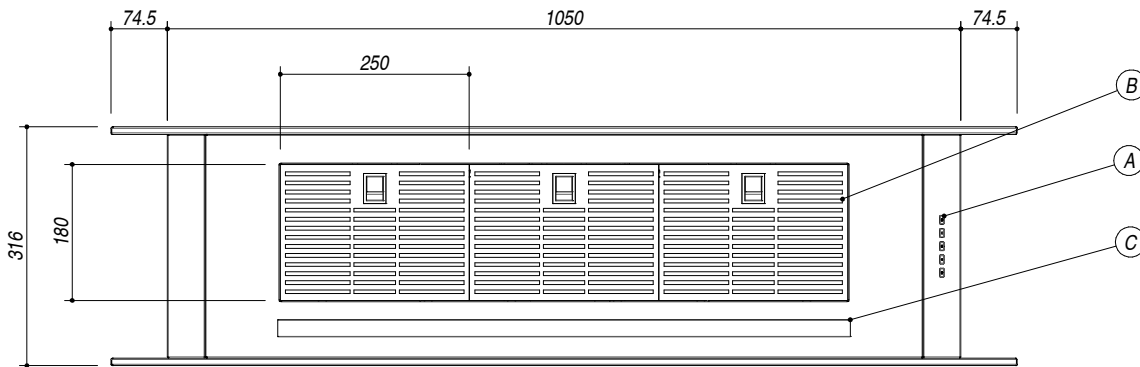
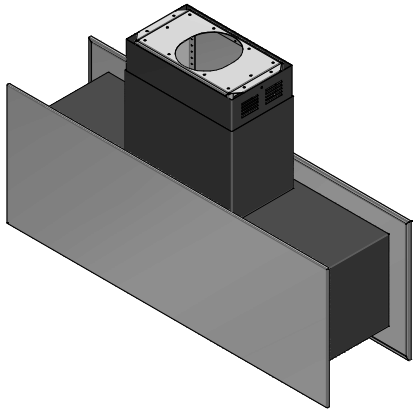

SCALA DISEGNO 1:10
DRAWING SCALE



TUTTE LE MISURE IN mm
ALL MEASURES IN mm

TOLLERANZA LINEARE: ± 0.5 mm
LINEAR TOLLERANCE

TOLLERANZA ANGOLARE: ± 0.2 °
ANGULAR TOLLERANCE